

# MATRIFlex<sup>®</sup>

## MP

### COMEDERO AUTOMÁTICO PARA MACHOS EN GALPONES DE PRODUCCIÓN *AUTOMATIC FEEDER FOR MALE IN PRODUCTION BREEDING HOUSES*

Plato plástico:

- Area para hasta 9 aves;
- Traba anti-giro y borde ancho evitan pérdidas;
- Con protección UV;
- Facil limpieza;
- Proyectado para cualquier tipo de alimento;
- Tolva para alimento con capacidad de 85kg;
- Antipercha y electrochoque opcional;
- Circuito con distribución uniforme de alimento;
- Sistema de suspensión por malacate eléctrico.

Plastic plate:

- Access up to 9 birds;
- Lock anti-turning and wide border avoid wastes;
- With UV protection;
- Easy to clean;
- Designed for any type of feed;
- Feed hopper with capacity of 85kg;
- Anti-perch with electroshock (optional);
- Circuit with uniform feed distribution;
- Suspension system by electric winch.



# MATRIFlex<sup>®</sup>

## MP

### DIMENSIONES DEL PLATO:

- A - Diámetro externo: 323mm
- B - Altura total: 289,5mm
- C - Altura del plato: 68mm
- D - Altura entre la base y el tubo con sinfín: 215,5mm
- E - Distancia entre aletas: 121mm

### PLATE DIMENSIONS:

- A - External diameter: 323mm
- B - Total height: 289,5mm
- C - Plate height: 68mm
- D - Height between the base and the tube with auger: 215,5mm
- E - Distance between flaps: 121mm

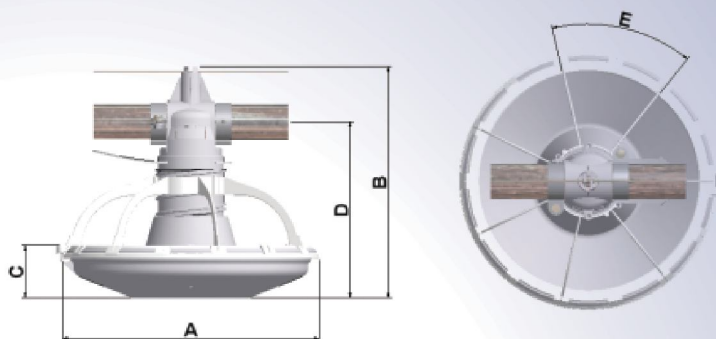

### COMPONENTES DEL COMEDERO FEEDER COMPONENTS



Accionamiento por Motorreductor  
(con plato final de línea),  
trifásico o monofásico 50/60hz  
*Drive by Gearmotor  
(with end of line plate),  
three-phase or single-phase 50/60hz*



Plato de control  
*Control plate*



Traba anti-giro  
*Lock anti-turning*



Tablero de control  
del electrochoque  
(opcional)

*Control pannel  
for electroshock  
(optional)*

ACCIONAMIENTO DRIVE	LARGO DEL TRAMO SEGMENT LENGTH	DISTANCIA DISTANCE
Motorreductor trifásico o monofásico 0,5cv 50/60hz <i>Gearmotor three-phase or single-phase 0,5cv 50/60hz</i>	6 metros <i>6 meters</i>	1,20m - 5 platos/tramo <i>1,20m - 5 plates/segment</i>

Matriz - Amparo / Head Office - Amparo  
Rua Sebastião Gonçalves Cruz, 477  
Amparo/SP | CEP 13904-904  
Fone: +55 (19) 3808-8800  
sac@casp.com.br

[www.casp.com.br](http://www.casp.com.br)

